

# ANALOG & DIGITAL COMMUNICATION TRAINERS

Product Guide

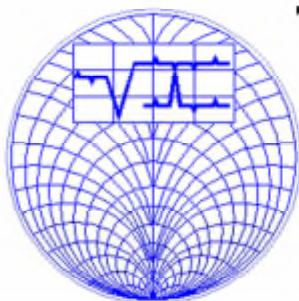

## Vi Microsystems Pvt. Ltd.,



Plot No : 75, Electronics Estate  
Perungudi, Chennai - 600 096.  
Ph : +91-44-2496 1842, 2496 1852  
Fax : +91-44-2496 1536  
E-mail : [sales@vimicrosystems.com](mailto:sales@vimicrosystems.com)  
Web : [www.vimicrosystems.com](http://www.vimicrosystems.com)

**Analog & Digital Communication Lab consist of following trainers**

1. PAM - PPM- PWM Modulation & Demodulation Trainer [VCT - 01]
2. Time Division Multiplexing PAM Modulation-Demodulation [VCT-02]
3. Amplitude Modulation & Demodulation Module [VCT-03]
4. AM Superheterodyne Receiver [VCT-06]
5. Pulse Code Modulation / Demodulation [VCT-07]
6. AM Transmitter [VCT-08] & Receiver [VCT-09] Trainer
7. Wireless Data Modem Transmitter [VCT-10A] & Receiver [VCT-10B]
8. FSK Transmitter and Receiver Trainer [VCT-10C & VCT-10D]
9. FM Modulation & Demodulation Trainer [VCT-11]
10. FM Transmitter [VCT-12] & Receiver Trainer [VCT-13]
11. FM Detector [VCT - 16]
12. ASK Modulation & Demodulation Trainer [VCT - 17]
13. FSK Modulation & Demodulation Trainer [VCT-18]
14. Three Way Cross over Network [VCT - 19]
15. Beat Frequency Oscillator Trainer [VCT-20]
16. PSK Modulation & Demodulation Trainer [VCT-21]
17. DSB-SC Modulation & Demodulation Trainer [VCT-22]
18. Analog Signal Sampling and Reconstruction Kit [VCT-23]
19. Audio Generator [VCT-24]
20. MIC Pre-amplifier [VCT-25]
21. AM Modulation / Demodulation Trainer [VCT-26]
22. Audio Power Amplifier [VCT-27]
23. PSK Transmitter & Receiver Trainer [VCT-28 A&B]
24. QPSK Modulation & Demodulation Trainer [VCT-29]
25. AM/FM Generator [VCT-30]
26. Automatic Gain Control [VCT-31]
27. Delta Modulation & Demodulation Trainer [VCT-32]
28. DPCM Modulation and Demodulation Trainer [VCT-34]
29. DTMF Telephone Trainer [VCT-35]
30. Bank of Filters [VCT-36]

31. Line Coding & Decoding Trainer [VCT-37]
32. Noise Signal Generator [VCT-38]
33. DPSK Modulation & Demodulation [VCT-39]
34. Level Converter [VCT-40]
35. EPABX Trainer [VCT-41]
36. SSB Modulation & Demodulation Trainer [VCT-42]
37. TDM-PCM Transmitter and Receiver [VCT-43]
38. FM Generation and Detector Trainer [VCT-44]
39. VSB Modulation and Demodulation [VCT-45]
40. MSK Modulation & Demodulation Trainer [VCT-46]
41. DSBSC Modulation and Demodulation with Cost as Loop [VCT-47]
42. White Noise Source [VCT-48]
43. Quadrature Amplitude Modulation & Demodulation [VCT-49]
44. Delta / Adaptive Delta / Sigma Delta Modulation & Demodulation [VCT-50]
45. Phase & Frequency Modulation / Demodulation [VCT-51]
46. Diode Detector [VCT-52]
47. Frequency Multiplier [VCT-55]
48. Frequency Synthesizer [VCT-56]
49. Series and Shunt Equalizer [TBET-78]

## 1. PAM - PPM- PWM MODULATION & DEMODULATION TRAINER [VCT - 01]

### Features :

- \* PAM-PPM-PWM Modulation and Demodulation Techniques, using Natural and Flat-top Sampling.
- \* Analog Sample, Sample and Hold and Flat-top outputs.
- \* Selectable 2 different sampling pulse frequencies on board.
- \* On board Sine wave generators.
- \* Voice communication using dynamic microphone and speaker
- \* On Board Filter and AC Amplifier
- \* Functional blocks indicated on board mimics
- \* Input-Output and Test points provided on board.
- \* Built in DC Power Supply
- \* Fully documented operating Manual



### Technical Specifications:

- \* Pulse Modulation Techniques
  - # Pulse Amplitude Modulation
  - # Pulse Width Modulation
  - # Pulse position Modulation
- \* On board Sampling
- \* Frequencies (Pulse) : 16 KHz, 32 KHz
- \* On Board Generators
  - # Sinewave 1KHz & 500Hz
  - # Amplitude (0-5)V, Tolerance  $\pm 5\%$

- \* Low Pass Filter : 4th Order BW Filter, Cut off frequency 3.4KHz
- Voice Communication: Voice Link using dynamic mic & speaker
- \* AC Amplifier : With Adjustable Gain control
- \* Interconnections : BS2 Sockets.
- \* Power : 230V  $\pm 10\%$ , 50Hz
- \* Accessories : Manual, Set of Patch cords, Microphone, Speaker

### Experiments:

1. Study of Pulse Amplitude Modulation using Natural and Flat Top sampling
2. Study of Sample, Sample & Hold, and flat top output in pulse Amplitude Modulation
3. Study of Pulse Amplitude Demodulation
4. Study of Pulse position modulation
5. Study of Pulse Position Demodulation
6. Study of Voice Communication using PAM, PPM, & PWM Techniques.
7. Study of pulse width modulation & Demodulation

## 2. TIME DIVISION MULTIPLEXING PAM MODULATION-DEMODULATION [VCT-02]



### Features:

- \* Crystal Controlled Clock
- \* On-board Sine Generator (Synchronized)
- \* On-board Pulse Generator

- \* 4 Analog input channels Sampled and Time division Multiplexed
- \* 4 Channel demultiplexer
- \* Generation of Clock at receiver by PLL system
- \* 4th Order Butterworth L.P Filter.
- \* Built-in Power supply

### Technical Specifications

- \* Crystal Frequency : 6.1 MHz
- \* Analog Inputs : 4 Channels
- \* Multiplexing : Time Division Multiplexing
- \* Modulation : Pulse Amplitude Modulation
- \* On-board Signal Generator
  - # 250Hz, 500 Hz, 1 KHz, 2 KHz (Sine Wave Synchronized to sampling pulse) Adjustable Amplitude and separate carryable DC level)
- \* Sampling Rate : 16 KHz/ channel
- \* Sampling Pulse : With Duty cycle 50%.(fixed)
- \* Clock Regeneration at receiver : Using PLL Low pass filter
- \* Cut-off Frequency : 3.4 KHz
- \* Test Points : 16
- \* Interconnections : 4mm Sockets
- \* Power : 230V  $\pm$ 10% 50Hz
- \* Accessories : Manual, set of patch cords, Line cord

### Experiments :

1. Study of Sampling & Reconstruction.
2. Study of Time Division Multiplexing and Demultiplexing
3. Study of PLL as Freq. Multiplier to generate clock from synchronous signal.
4. Study of three Modes of operation to regenerate original signal.
  - a) 3 wire system between transmitter and receiver (clock, sync, information)
  - b) 2 Wire system (information, sync) Clock regenerated at receiver.
  - c) Single wire system (information only). Clock and Sync regenerated at receiver

## 3. AMPLITUDE MODULATION & DEMODULATION MODULE (VCT-03)

### Features:

- \* Amplitude modulating circuit. Outputs and Inputs are provided in the proper terminals.
- \* Carrier and modulating signals are provided in the unit with frequency variable.
- \* In-built regulated power supply
- \* On-board sine wave generator
- \* On-board modulation circuit
- \* On board envelope detector



### Technical Specifications :

- # Modulating Signal : (300Hz-10KHz) (0-5)V Variable
- # Carrier Signal : 1.5KHz - 50KHz (0-5)V Variable
- # Modulators : 1. Ring Modulator  
2. Transistor based Modulator
- # Demodulation : Using envelope detector

### Experiments :

- # Study of Amplitude modulation using Ring modulator
- # Study of Amplitude Modulation using transistor based modulator
- # Study of AM demodulation using envelope detector

#### 4. AM SUPERHETERODYNE RECEIVER [VCT-06]

##### Features :

- \* On board AM Generator
- \* Testpoints to study different waveforms like
  - # IF Stage output
  - # Antenna Output
  - # Mixer Output
  - # Demodulated output
- \* Provide Audio Power amplifiers
- \* In-built DC Power Supply
- \* Discrete Circuit to study superheterodyne receiver
- \* On board sine wave generator



##### Technical Specifications :

- \* Intermediate Frequency : 455 KHz
- \* Input circuits
  - i. Pre selector
  - ii. Mixer with Local Oscillator
  - iii. IF Amplifier - 1
  - iv. IF amplifier - 2
  - v. IF Amplifier - 3
- \* Tuning : Ganged tuning
- \* Detector : Diode detector (DSB)
- \* Audio Output : Audio Amplifier
- \* Receiving media : Ferrite core
- \* AM Generator : Carrier range (1 to 2 MHz)
- \* Sine Wave Generator : 300Hz - 10KHz

##### Experiments

- \* Study of AM receiver
- \* Study of selectivity
- \* Study of AGC Circuit

#### 5. PULSE CODE MODULATION/ DEMODULATION [VCT-07]

##### Features :

- \* In-built sinewave generator
- \* Test points to study different waveforms
- \* In-built DC Power supply



##### Technical Specifications :

- \* Crystal Frequency : 6.14 MHz
- \* Onboard Generator
  - # Sinewave generator (200Hz)
  - # Variable DC Source
- \* Sampling Frequency : 32 KHz
- \* LPF : Fourth order butterworth filter

##### Experiments

- \* Study of ADC
- \* Study of Pulse Code Modulation
- \* Study of Pulse Code Demodulation

## 6. AM TRANSMITTER [VCT-08] & RECEIVER [VCT-09] TRAINER

### TRANSMITTER

#### Features :

- \* On board carrier generator (Variable)
- \* In-built regulated power supply
- \* On-board sine wave generator
- \* On board Audio and Mic pre-amplifier



#### Specifications :

- \* Carrier generator Range : 1-2MHz
- # Amplitude : (0-8)V
- \* Sine wave generator Range : 300Hz-10KHz
- # Amplitude : (0-5)V
- \* Mic pre amplifier Gain : 20
- \* Audio Amplifier Gain : 100

### RECEIVER

#### Features

- \* On board Audio power amplifier
- \* On board filter and AM Detector
- \* In built regulated power supply



#### Specifications :

- \* Audio power amplifier (Gain : 100)
- \* Demodulator envelope detector
- \* Band pass filter (BW : 10KHz)
- \* RF Amplifier tunable from (1 - 2) MHz

#### Experiments

- \* To study AM technique using base modulator
- \* Calculation of Modulation index
- \* Study of various level of modulation (under, critical, over)
- \* Study of AM demodulation using envelope detector
- \* Transmission of voice signal

## 7. WIRELESS DATA MODEM TRANSMITTER [VCT-10A] & RECEIVER [VCT-10B]

### a. Wireless Modem Transmitter Module :



- \* Digital data from the  $\mu\text{P}/\mu\text{C}$  kit transmitted through RS232 serial interface
- \* Built-in power supply
- \* Digital data are modulated through FSK technique
- \* RF Transmitter module provided to Transmit the FSK data
  - # Carrier 433.92 MHZ
  - # Amplitude Modulation
- \* Telescopic antenna to transmit the signal

**b. Wireless Modem Receiver Module :**



- \* Telescopic antenna to receive the RF signal
- \* RF Receiver module provided to Receive the FSK data (Carrier 433.92MHZ)
- \* Amplitude Modulation
- \* Built-in power supply
- \* Digital data are demodulated through FSK technique
- \* Reconstructed serial digital data are sent to the  $\mu\text{P}/\mu\text{C}$  kit

**Note : Two Nos. of our Mp/Mc Kit should be provided by the institution to conduct the above experiment (or) optionally to be purchased.**

**Experiments:**

- \* Communication of digital data upto 300 BPS
- \* Study of FSK modulation
- \* Study of FSK Demodulation

- \* Transmission and reception of digital signal between
  - i. 8 bit microprocessor
  - ii. 16 bit microprocessor
  - iii. 8 bit microcontroller
  - iv. DSP
  - v. PC

**8. FSK TRANSMITTER AND RECEIVER TRAINER (VCT-10C & VCT-10D)**

**Transmitter Features:**

- \* Three types of I/P sources.
  - # Manual Input
  - # Square input
  - # RS232 Input
- \* FSK Modulator with,
  - # Mark Frequency : 1070 Hz
  - # Space Frequency : 1270 Hz
- \* Transmitter
  - # Amplitude Modulation
  - # Carrier Frequency : 433.92 MHZ
- \* Whip Antenna to transmit RF signal
- \* Built in power supply

**Receiver Features:**

- \* Whip Antenna to receive the RF signal
- \* RF Receiver module
  - # Amplitude Demodulation
  - # Carrier Frequency : 433.92 MHZ
- \* PLL Based FSK Demodulator
- \* Output provided through BS2 connector and serial port
- \* Built-in power supply

**Experiments:**

- \* Communication of digital data upto 300 BPS
- \* Study of FSK modulation
- \* Study of FSK Demodulation
- \* Transmission and reception of digital signal between
  - i. 8 bit Microprocessor
  - ii. 16 bit Microprocessor
  - iii. 8 bit Micro-controller
  - iv. DSP
  - v. PC

## 9. FM MODULATION & DEMODULATION TRAINER [VCT-11]

- \* On board Sinewave generator
- \* Provision to study modulation & demodulation in the same unit
- \* Test points to study different waveforms
- \* In-built Audio power amplifier
- \* Mic pre Amplifier
- \* Built-in power supply



### Technical Specifications

- # Sine Wave generator : Frequency - 100Hz to 1.2 KHz with amplitude adjustable, (0-5V)
- # FM Modulator : Direct FM
- # Carrier frequency
  - Low Frequency : 20 KHz
  - High Frequency : 367 KHz
- # FM Demodulator : PLL Detector, Quadrature Detector, Foster Seelay discriminator / Phase Discriminator, Ratio Detector are provided.
- # Audio power amplifier : Gain 100
- # Mic pre amplifier : Gain 20.

### Experiments:

- \* Study of FM using direct frequency modulation
- \* Study of Frequency demodulation using
  - i. PLL Detector
  - ii. Quadrature Detector
  - iii. Foster Seelay discriminator / Phase Discriminator
  - iv. Ratio Detector

## 10. FM TRANSMITTER [VCT-12] & RECEIVER TRAINER [VCT-13]

### Transmitter Features :

- \* On board carrier generator (Fixed)
- \* In built regulated power supply
- \* On board sine wave generator
- \* On board Audio and Mic pre amplifier



### Specifications :

- \* Carrier Frequency : 100 MHz
- # Amplitude : (0-8)V
- \* Sine wave generator
  - Range : 300Hz-10KHz
  - # Amplitude : (0-5)V
- \* Mic pre amplifier
  - Gain : 20
- \* Audio Amplifier
  - Gain : 100

### Receiver Features:

- \* On-board audio power amplifier
- \* On board Band pass filter
- \* In-built DC regulated power supply



### Specifications:

- \* Audio power amplifier (Gain 100)
- \* Band pass filter : BW 10KHz
- \* FM Demodulator tunable from 88 MHz to 108 MHz

### Experiments

- Study of Frequency modulation
- Study of Frequency demodulation
- Transmission of voice signal using FM

### 11a. DATA FORMATTING AND CARRIER MODULATION TRAINER (VCT-14A)

#### Feature:

- \* On board Data Generator circuit
- \* On board Carrier Generator Circuit.
- \* Different data condition formats.
- \* Different Modulator.
- \* Unipolar to Bipolar converter.
- \* Mimic diagram.
- \* Various test points.
- \* Variable off set.
- \* Detailed Documentation.
- \* Power supply.

### Technical specifications:

- \* Repeatable binary data : 480KHz.
- \* 8 bit programmable binary data : 240KHz.
- \* Data formats : NRz (L), NRz (M), AM1, RB Biphase (Manchester), Biphase method (mark)
- \* Modulation method : ASK, FSK, BPSK
- \* Modulator Type : Balanced modulator.
- \* Carrier : Sinewave synchronized to transmitted data. At 1.44MHz, 960KHz ( 0 degree phase ) 960KHz (90 deg. Phase).
- \* Connector : uninsulated socket.
- \* Power : AC 230V / 50Hz.  
DC  $\pm 12V$ , +5, GND.

### Experiments:

- To study the Data formats NRZ (L), NRZ (M) Rz, AM1, RB, Biphase (Manchester), Biphase (M)
- To study the ASK, FSK, BPSK, modulation.

### 11b. Carrier Demodulation and Data Reformatting Trainer (VCT-14B)

#### Feature:

- \* Different data Reformatters.
- \* Different carrier demodulation section.
- \* Clock recovery circuit.
- \* Mimic diagram.
- \* Power supply.
- \* Various test points.
- \* Detailed Documentation.

### Technical specifications:

- \* Reformatting options : NRz (M), Rz, AMI, RB Biphase (Manchester), Biphase (mark)

- \* Carrier demodulation
  - # ASK : Rectifier diode.
  - # FSK : PLL detector.
  - # BPSK : Square loop.
- \* Clock recovery : PLL
- \* Connector : Uninsulated socket.
- \* Power supply
  - # AC 230V / 50Hz.
  - # DC  $\pm 12V$ , +5V, GND.

**Experiments:**

1. To study the carrier De modulation.
2. To study the different Data Reformation.

**11. FM DETECTOR (VCT - 16)**

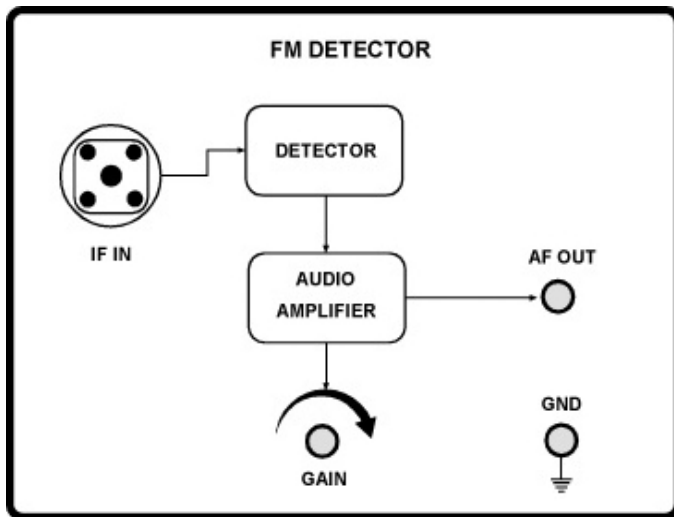

**Technical Specification**

- \* Built in FM Receiver (CXA 1619)
- \* Intermediate frequency : 10.7 MHz
- \* Built in Audio power Amplifier
  - # Gain : 25
- \* Built-in Power supply
- \* Detailed Documentation

**Experiment**

- \* To receive the FM signal using FM detector

**12. A S K M O D U L A T I O N & DEMODULATION TRAINER [VCT-17]**

**Features :**

- \* On board data generator circuit
- \* Auto/Manual mode (Data Generation)
- \* External patching provision provided between the modulator and demodulator
- \* Built-in power supply
- \* Modulator and demodulator are separately provided.
- \* Easy interconnections are made by patch cords



**Technical Specifications :**

- \* Mode : Auto / Manual
- \* Input Data Rate : 800Hz to 2 KHz
- \* Any external TTL compatible sequence with frequency upto 2.1KHz
- \* Carrier Frequency : 20KHz
- \* Power supply ratings : 230V $\pm$ 10%, 50Hz

**Experiment**

- \* Study of ASK modulation
- \* Study of ASK Demodulation

### 13. FSK MODULATION & DEMODULATION TRAINER [VCT-18]

**Features :**

- \* Three types of I/P sources.
  - # Manual Input
  - # Square input
  - # RS232 Input
- \* FSK Modulator with,
  - # Mark Frequency : 1070 Hz
  - # Space Frequency : 1270 Hz



- \* PLL Based FSK Demodulator
- \* Output provided through BS2 connector and serial port
- \* Built-in power supply

**Experiments:**

- \* Communication of digital data upto 300 BPS
- \* Study of FSK modulation
- \* Study of FSK demodulation
- \* Transmission and reception of digital signal between
  - i. 8 bit microprocessor
  - ii. 16 bit microprocessor
  - iii. 8 bit microcontroller
  - iv. DSP
  - v. PC

### 14. THREE WAY CROSS OVER NETWORK (VCT - 19)

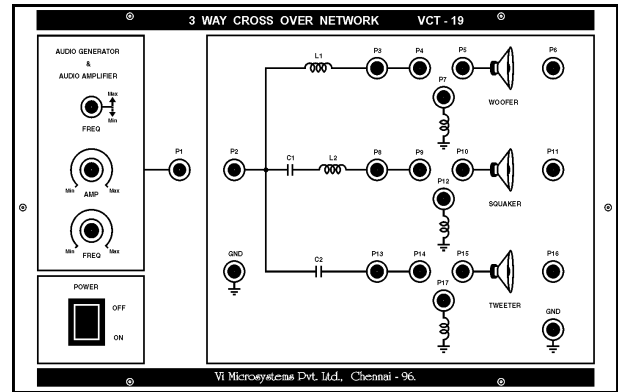

**Technical Specification**

- \* Onboard Audio generator
  - # Frequency : 10 Hz to 20 KHz
  - # Amplitude : 0 - 5V
- \* Frequency of Operation
  - # Woofer : 16 Hz to 500 Hz
  - # Squaker : 500 Hz to 2.5 KHz
  - # Tweeter : 2.5 KHz to 20 KHz
- \* Built in power supply
- \* Detailed documentation provided

**Experiments**

- \* To study the operation of Three way Cross over network and to plot the frequency response of
  - # Woofer
  - # Squaker
  - # Tweeter

### 15. BEAT FREQUENCY OSCILLATOR TRAINER [VCT-20]



### Technical Specifications :

- \* Sine source
  - # Fixed Frequency : 10 KHz
  - # Variable Frequency : 9 KHz to 10 KHz
- \* Transistor based mixer provided
- \* Built-in amplifier
- \* Power Supply
  - #  $\pm 12V$  DC, 200 mA
  - # Unit is operated using 230V AC power

### Experiments

- \* To study the operation of Beat Frequency Oscillator

### 16. P S K M O D U L A T I O N & DEMODULATION TRAINER [VCT-21]

- \* Type of Modulator : Balance Modulator
- \* Type of Demodulator : Balance Demodulator
- \* Binary inputs
  - # 8-bit data length
  - # 50KHz, clock
- \* Carrier inputs
  - # Frequency : 200KHz
  - # Amplitude : 2V PP
- \* Supply Ratings
  - # AC Input (230V  $\pm 10\%$ , 50Hz)
  - # DC output (+12V, -12V, +5V, GND)



### Experiments

- \* Study of PSK modulation
- \* Study of PSK Demodulation

### 17. D S B - S C M O D U L A T I O N & DEMODULATION TRAINER [VCT-22]



- \* Carrier Frequency : 10KHz - 200KHz (approx.) Variable
- \* Amplitude : 0.3V to 4.2V
- \* Modulating Frequency : 1KHz - 2.2KHz (Variable)
- \* Amplitude : 0 - 4.5V
- \* Modulator : Balance Modulator with offset
- \* Demodulator : Balance Demodulator with variable gain
- \* Built-in power supply ( $\pm 12V$  DC/500mA)
- \* Detailed Experimental Manual.
- \* Test and Monitoring point
- \* Easy interconnection are made by patch chord

### Experiments

- \* Study of DSBSC modulation
- \* Study of DSBSC demodulation

### 18. ANALOG SIGNAL SAMPLING AND RECONSTRUCTION KIT [VCT-23]

#### Features :

- \* Analog sampled outputs and sampled "Hold" outputs
- \* Active low pass Butterworth filters - 2nd order
- \* On board 8 different sampling frequencies
- \* Duty cycle variation in steps of 10% upto 100%

- \* 25Hz, 250Hz, 500Hz on board synchronized sinewave generator
- \* Various test and monitoring points.



**Technical Specifications :**

- \* On board sampling frequencies
  - # External : 320KHz, 160KHz, 80KHz, 40KHz, 20KHz, 10KHz, 5KHz, 2.5KHz
  - # Internal : 32KHz, 16KHz, 8KHz, 4KHz, 2KHz, 1KHz, 500Hz, 250Hz
- \* Sampling : i. Natural Sampling  
ii. Flattop Sampling
- \* Duty cycle : 10% to 100% in 10% steps
- \* Low pass filter type : Butterworth 2nd order
- \* Cut-off frequency : 3.4KHz
- \* On board sinewave signal : 25Hz, 250Hz, 500Hz
- \* Interconnection: 2mm banana socket
- \* Power Supply : +5V/500mA, ±12V DC, 300mA.

**Experiments**

- \* Study of signal sampling and reconstruction
- \* Study of Nyquist criteria and aliasing
- \* Study the effect of reconstructed waveform using sample and hold circuit
- \* Study the effect of reconstructed waveform using Flattop sampling

- \* Study the effect of reconstructed waveform on changing the duty cycle
- \* Comparison of frequency response of 2nd order and 4<sup>th</sup> order butterworth filter

**19. AUDIO GENERATOR [VCT-24]**



**Technical Specifications**

- \* 8038 based audio generator
- \* Built-in Buffer circuit
- \* Frequency : 300 Hz to 3.4 KHz
- \* Amplitude : 0 - 5 V<sub>pp</sub>
- \* Power supply provided
- \* BNC type output connector provided

**20. MIC PRE-AMPLIFIER [VCT-25]**



**Technical Specifications**

- \* Transistor based MIC Pre-Amplifier
- \* Gain : 20
- \* Power supply provided
- \* I/P & O/P connectors provided

## 21. AM MODULATION/DEMODULATION TRAINER [VCT-26]



- \* Sine Wave generators :
  - # Modulating signal  
Frequency Range-100Hz to 1KHz (Approx)
  - # Carrier Signal  
Frequency Range-10KHz to 115KHz
- \* One modulator section using multiplier IC
- \* Demodulation section using precision envelope detector
- \* Built-in power supply
- \* Line Chord, Set of Patch chords and manual.

### Experiments

- \* Study of AM modulation
- \* Study of AM demodulation

## 22. AUDIO POWER AMPLIFIER [VCT-27]



### Technical Specification

- \* TBA810 based audio power amplifier
- \* Gain : 100, Gain can be varied by POT
- \* Power supply provided
- \* I/P & O/P connectors provided

## 23. PSK TRANSMITTER & RECEIVER TRAINER (VCT-28 A&B)



### Features:

- \* On board data generator kit
- \* Auto/Manual data generator circuits
- \* Built-in power supply
- \* Modulator and demodulator are separate
- \* Easy interconnections are made by patch cord
- \* Modulated data go through wire or RF by selector switch



### Technical Specifications :

- \* Modulating data inputs : 1 KHz
- \* 180° Phase shift
- \* Carrier : 2KHz
- \* Continuous PSK Modulation technique is used
- \* 8 Bit programmable data
- \* Whip Antenna for transmission and reception

### Experiments

- \* To study PSK modulation
- \* To study PSK demodulation
- \* Transmission and reception of digital data using PSK technique.

### 24. QPSK MODULATION & DEMODULATION TRAINER [VCT-29]



- \* On board modulator / Demodulator
- \* Carrier frequency (10KHz)
- \* Modulating Signal
  - # Programmable 4 bit data
  - # Clock as a modulating signal - 5KHz
- \* Modulator - Balance Modulator
- \* Demodulation - Balance Demodulator
- \* Schematic diagram provided in the front panel
- \* Test points provided
- \* Patch chords provided
- \* On board power supply
- \* Detailed documentation.

### Experiments:

- \* Study of QPSK modulation
- \* Study of QPSK demodulation

### 25. AM/FM GENERATOR [VCT-30]

- \* AM/FM Selector
- \* Int/Ext Input Selector
- \* Built in Power Supply
- \* Output Terminated in BNC Socket



### Technical Specification :

- \* Operating Modes : Internal, External
- \* Modulation : AM, FM
- \* Carrier Frequency (Built-in) : 100 KHz - 500 KHz (Variable)
- \* Variation of Carrier Frequency :  $\pm 2\%$  over the range
- \* Modulating Signal
  - # Internal Mode : 3KHz
  - # External Mode : 200Hz to 20KHz
- \* Operating Temp. : 0-45°C
- \* Power : 230V  $\pm 10\%$ , 50Hz
- \* Dimensions(in mm) : 185.209 x 65.102
- \* Weight : 1Kg (Approx)
- \* Fuse : 500mA

### 26. AUTOMATIC GAIN CONTROL[VCT-31]

#### Technical Specifications

- \* Combination of transistor, FET, Buffer circuits
- \* Negative feedback
- \* Input / Output connector provided
- \* External function generator
  - # Frequency : 1KHz to 10 KHz
  - # Amplitude : 0 - 5V
- \* Built in power supply
- \* Detailed Documentation

## Experiments

To study the technic of AGC

### 27. DELTA MODULATION & DEMODULATION TRAINER [VCT-32]

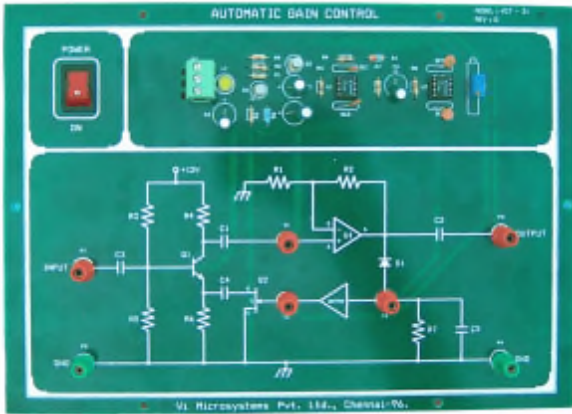

#### Features :

- \* On board modulating signal - 2KHz sine.
- \* Modulation and demodulation in single unit.
- \* Schematic diagram provided in the panel
- \* Necessary test points provided.
- \* Built-in Power supply



#### Technical Specifications :

- \* Modulating signal Frequency : 300Hz - 2KHz
- \* Amplitude : 0-5V
- \* Sampling Frequency : 1-50KHz

- \* Filter : Second order butterworth low pass filter
- \* Coding : NRZ
- \* Patch chords provided.
- \* Detailed documents provided.

#### Experiment:

- \* Study of delta modulation
- \* Study of delta demodulation

### 28. DPCM MODULATION AND DEMODULATION TRAINER [VCT-34]



The VCT-34 DPCM system comprises the differential pulse code modulator and Demodulator on the same board. The analog signal generator is provided for doing experimental exercises. LED options provided for studying signal flow through various sections of modulator and demodulator.

#### SPECIFICATION

- \* Both Modulator and Demodulator on same board.
- \* Crystal based clock generator.
- \* On-Board synchronized sine wave generator.
- \* On-Board Fourth order Butter-worth low Pass Filter.
- \* Mimic diagram provided in the panel
- \* Built-in Power Supply.

## TECHNICAL SPECIFICATION

Clock Generation : Crystal Based  
Crystal Frequency : 16MHz  
Input Source Type : Sine wave  
    Amplitude : 0 to 1.5Vpp  
    Frequency : 1KHz  
DC Voltage : 0 to 1.5V  
Sampling Frequency : 8KHz  
Test Points : 17  
Filter Type : Butter worth, 4<sup>th</sup> order  
Supply Voltage :  $\pm 5V, \pm 12V$   
Weight : 2.5Kg (approx.)

## LIST OF EXPERIMENTS

- \* Study of Differential PCM Modulation and Demodulation using DC signal.
- \* Study of Differential PCM Modulation and Demodulation using Sine wave.

### 29. DTMF TELEPHONE TRAINER (VCT-35)



#### Specifications :

- \* ON/OFF Hook Switch, Dialer, Ringer, Speech processing section
- \* DTMF (Tone) and Pulse dialing
- \* Special Test points provided to observe isolated dual frequency output during DTMF dialing.
- \* Built-in power supply
- \* Necessary test points & LEDs provided to observe various signals
- \* Facility to fault creation for each block/each circuit
- \* Mimic diagram provided in the panel for easy understanding of various blocks.
- \* Detailed Documentation.

#### Technical Details :

- \* Standalone operation
- \* Handset connection port (RJ45)
- \* 4x4 Matrix Keyboard
- \* DTMF and pulse dialing, ON/OFF hook switch
- \* Ringer volume control
- \* Indication for Line ON/Pulse Dialing indication Tone, Dialing indication
- \* 4 Nos. of Switch Faults.

#### Experiments

- \* To study telephone line voltage
- \* Study of DTMF generation
- \* Study of DTMF receiver using switched faults
- \* Voice communication using DTMF receiver

### 30. SPECTRUM ANALYSER USING BANK OF FILTERS [ VCT-36]



#### Technical Specifications

- \* 6 Different types of filters provided in the range of 0.5, 0.75, 1, 1.25, 1.5, 1.75 MHz
- \* Rotary switch provided to select the range
- \* 2 mm sockets provided to view the outputs
- \* Detailed Documentation

#### Experiments

- \* To study the Bank of Filters using various filter range.

### 31. LINE CODING & DECODING TRAINER [VCT-37]:

#### Features:

- \* On board clock generator.
- \* On board PRBs data generator.
- \* On board different data formatting.
- \* On board different data reformatting.
- \* In built power supply.
- \* Test and monitoring points.
- \* Mimic diagrams are provided in the panel.
- \* Technical manual is provided.

#### Technical Specification

- \* Different data formatting.
  - # Unipolar return to zero format.
  - # Unipolar non return to zero format.
  - # Polar return to zero format.
  - # Polar non return to zero format.
  - # Alternate mark inversion (AM1) signaling format.
  - # Bipolar non return to zero format.
  - # Manchester format.
- \* On board clock generator
  - # Frequency range - 2KHz to 5KHz.
  - # Amplitude - 0 to 5V.
- \* On board PRBs data generator
  - #  $2^{4-1}$  long - 15 bit sequence.

### 32. NOISE SIGNAL GENERATOR (VCT-38)



### Technical Specifications

- \* Built in Clock Generator
  - # Frequency : 100 KHz - 1MHz
  - # Step size : 100 K
- \* Rotary switch provided to select the clock
- \* Three types of noise generator
  - # PNS Generator
  - # Optimized semi conductor noise
  - # White noise
- \* Analog & Digital Adder provided to study the Three noise sources

### 33. DPSK MODULATION & DEMODULATION (VCT-39)



### Technical Specifications

- \* Binary data
  - i. Clock data
    - # Frequency : 5KHz
    - # Amplitude : 5V
  - ii. 4 Bit Programmable data
    - # Frequency : 5KHz
    - # Amplitude : 5V
- \* Carrier Signal
  - # Frequency : 10KHz
  - # Amplitude : 5V<sub>pp</sub>
- \* Onboard differential circuit
- \* Modulator - Balanced modulator
- \* De-Modulator - Balanced demodulator
- \* Onboard gain control for Modulation
- \* Builtin Power supply
- \* Detailed Documentation

### 34. LEVEL CONVERTER [VCT-40]

#### Technical Specifications

- \* Clock Frequency : 120 Hz to 2 KHz
- \* Amplitude : Symbol 1 - +5 V  
Symbol 0 - 0 V
- \* M-ary encoder : 2-4 level converter  
2-8 level converter
- \* Built in Power supply



#### Experiments

- \* To encode two binary bits into 4 amplitude levels.
- \* To encode 3 binary bits into 8 amplitude levels

### 35. EPABX TRAINER [VCT-41]



#### Technical Specifications

- \* 2 dot line with 6 extension line
- \* Fully non blocking speech path
- \* Isolation for trunk line and extension line
- \* 89C51 Based CPU card
- \* Built in DTMF Generator
- \* Drivers provided for both PNT and Intercom lines
- \* Program memory - RAM.
- \* LED provided to view the status of line and CPU.
- \* Dial tone, Busy tone, Ring tone, Back tone, hold or music etc.
- \* 2mm socket provided to view various waveform.
- \* Built in Power Supply
- \* Detailed Documentation.

#### Experiments:

- \* To study the operation of EPABX trainer and to view the various waveforms

### 36. SSB MODULATION & DEMODULATION TRAINER [VCT-42]



#### Features :

- \* On board Modulating Signal
- \* On board Carrier Signal
- \* Balanced Modulator
- \* Balanced Demodulator
- \* Built in Power Supply ( $\pm 12V$ )

### Technical Specification:

- \* Modulating signal : 100KHz to 181 KHz
- \* Carrier Signal : 800KHz to 1500KHz
- \* Modulator with offset adjustable
- \* Filter : 3rd order butterworth filter
- \* Accessories : Line chord, Set of patch chords and manual.

### Experiments

- \* Study of SSB Modulation
- \* Study of SSB Demodulation

## 37. TDM-PCM TRANSMITTER AND RECEIVER (VCT-43)

### Transmitter



### Receiver



### Features:

- \* Separate Transmitter and Receiver boards
- \* Two channel time-division multiplexed PCM.
- \* Two operating speeds:
  - # FAST for real time operation
  - # SLOW for examination of control signal & data flows on LED'S
- \* Two synchronized sinewave and DC voltage generator.
- \* Error-check code options:
  - # ODD / EVEN parity for single bit error detection
  - # HAMMING code for single bit error detection and correction.
- \* Eight switched faults at transmitter and Receiver.
- \* Mimic on-board diagram.
- \* Built - in power supply.

### Technical specification:

- \* Clock Generation : Crystal (12MHz).
- \* Operating modes
  - # FAST : 480KHz of clock frequency
  - # SLOW : 0.852 Hz of clock frequency.
- \* On-board signal generators
  - # Sinewave: 1KHz & 2KHz (FAST mode only)
  - # DC : 8Vpp (FAST & SLOW mode)
- \* ERROR check codes
  - # ODD / EVEN PARITY, HAMMING CODE.
- \* Frame Synchronization
  - # PN sequence - 15 bit length.
- \* Switched faults : Four number on every transmitter & receiver boards.
- \* Clock recovery : Phase clocked loop (PLL)
- \* Low- pass filter : Fourth-order Butter worth, 3.4KHz of cut- off frequency
- \* Power : 230V,  $\pm 10\%$ , 50Hz.

### Experiments:

1. To Study the Time Division multiplexing and Demultiplexing.
2. To Study the pulse code modulation
3. To Study the Error control coding
4. To Study the frame synchronization
5. To Study the PLL.

### 38. FM GENERATOR AND DETECTOR TRAINER (VCT-44)

This trainer kit is used to study the FM Generation and Detection technic using various modulator and demodulator type.



- \* On board signal generator
- \* On board carrier signal generator
- \* Various test and monitoring Points are Provided
- \* In build Power supply
- \* Mimic diagram
- \* Detailed Documentation
- \* Connecting cable.

#### Specification:

- \* Modulating Signal
  - # Frequency : 2KHz to 20KHz
  - # Amplitude : 5Vpp
- \* Carrier Signal
  - # Frequency : 100KHz
  - # Amplitude : 1Vpp
- \* Modulator
  - i) Reactance Modulator
  - ii) Balanced Modulator
  - iii) VCO Based Modulator
- \* Demodulator
  - i) PLL Based Demodulator
  - ii) Balanced Demodulator
- \* Connecting Cable : SP7 patch card
- \* Supply Voltage
  - # AC : 230V/50Hz
  - # DC :  $\pm 12V$ , GND.

### Experiments:

To study the FM Generation & Detection technic using various modulator and Demodulator type.

### 39. VSB MODULATION AND DEMODULATION (VCT-45)



#### Feature:

- \* On board signal generator.
- \* On board carrier signal generator.
- \* Various test and monitoring points are provided.
- \* In build power supply.
- \* Mimic diagram.
- \* Detailed documentation
- \* Connecting cable.

#### Specification:

- \* Modulating signal
  - # Frequency : 10KHz to 200KHz.
  - # Amplitude : 3Vpp.
- \* Carrier signal
  - # Frequency : 650KHz to 1.2MHz.
  - # Amplitude : 1Vpp.
- \* Modulator : Balanced modulator.
- \* Demodulator : Balanced de modulator.
- \* Connecting Cable : SP7 patch chords.
- \* Supply Voltage
  - # AC : 230V/50Hz.
  - # DC : +12V, - 12V, GND.

### Experiments:

To study the function of VSB modulation & Demodulation.

#### 40. MSK MODULATION & DEMODULATION TRAINER (VCT-46)



##### Feature:

- \* On board Clock Generator.
- \* On board Programmable Data Generator.
- \* Variable mark and space frequency selector.
- \* Mimic diagram.
- \* Phase lock Detector.
- \* Connecting cable.
- \* Power supply.
- \* Detailed documentation

##### Specification:

- \* Modulating signal:
  - # Reportable Binary data : 360 bps to 420 bps (variable).
  - # 4 bit programmable data : 360 bps to 420 bps (variable).
- \* Carrier
  - # Mark frequency : 1200Hz to 1300Hz (Approx)
  - # Space frequency : 1000Hz to 1100Hz (Approx)
- \* Modulator type : Voltage controlled oscillator.
- \* Demodulator type : PLL
- \* Inter connection connector
  - # Uninsulated socket
- \* Cable : SP7 patch chords

##### Power supply:

- \* AC: 230V / 50Hz, 5A.
- \* DC: +5V, +12V, -12V, & GND.

##### Experiments:

1. To study the MSK Modulation & Demodulation.

#### 41. DSBSC MODULATION AND DEMODULATION WITH COST AS LOOP (VCT-47)

##### Feature:

- \* On board signal generator.
- \* On board carrier signal generator.
- \* Various test and monitoring points are provided.
- \* In build power supply.
- \* Mimic diagram.
- \* Detailed documentation
- \* Connecting cable.



##### Specification:

- \* Modulating signal
  - # Frequency : 50KHz to 100KHz.(Approx)
  - # Amplitude : 5Vpp.
- \* Carrier signal
  - \* Frequency : 1MHz.
  - \* Amplitude : 2Vpp.
- \* Modulator type: Balanced modulator.
- \* Demodulator type : Cost as loop.
- \* Connecting Cable : SP7 patch chords.
- \* Supply Voltage
  - # AC : 230V/50Hz.
  - # DC : +12V, - 12V, GND.

### Experiments:

To study the function of DSBSC modulation and Carrier recovery (Costa's loop) demodulation.

#### 42. WHITE NOISE SOURCE (VCT- 48)



### Feature:

- \* Inbuilt power supply provided.
- \* Variable Gain controller provided.
- \* Optional test points provided.

### Specification:

- \* White noise generator : Output amplitude adjustable (Max 3 Vpp).
- \* Maximum frequency : 150KHz
- \* Output connector : BNC connector & BS2connector
- \* Power supply : AC 230V / 50Hz
- \* Operating temperature : 0 - 40°
- \* Dimensions : L150 mm × W 100 mm × H60 mm
- \* Weight : 1kg.

#### 43. QUADRATURE AMPLITUDE MODULATION & DEMODULATION (VCT-49)



### Feature:

- \* In built Data & Carrier Generator.
- \* In built modulator & Demodulator.
- \* Various test points.
- \* Internal power supply.
- \* Mimic diagram.
- \* Connecting Cable.
- \* Detailed documentation.

### Specification:

- \* Programable Data Generator : 1460 bps.
- \* Carrier Generator
- \* Frequency : 5KHz.
- \* Amplitude : +2Vpp.
- \* Modulator type : Balanced modulator.
- \* Demodulator type : Balanced demodulator.
- \* Adder type : Analog Adder.
- \* Inter connection connector
  - # Uninsulated socket.
- \* Cable : SP7 patch chords.
- \* Power Supply
  - # AC : 230V/50Hz.
  - # DC : ±5V, ±12V, GND.

### Experiments:

To study the Quadrature Amplitude modulation and demodulation.

#### 44. DELTA / ADAPTIVE DELTA / SIGMA DELTA MODULATION & DEMODULATION (VCT-50)



**Feature:**

- \* In build CLOCK Generator.
- \* Sine wave Generator.
- \* Filter with variable gain controller.
- \* Various test points.
- \* Mimic diagram.
- \* Power supply
- \* Detailed documentation

**Specification:**

- \* Clock Generator : Cry stall (16MHz)
- \* Sampling frequency : 8 K H z , 1 6 K H z , 32KHz & 64KHz.
- \* Sine wave frequency : 500Hz and 1000Hz.
- \* Integrator : Variable integrator gain.
- \* Filter : Butter worth 4th order low pass filter.
- \* Power supply : 230V,50Hz.
- \* Test Points : 27

**List of Experiments:**

- \* To Study the delta modulation & Demodulation.
- \* To Study the Adaptive delta modulation & Demodulation.
- \* To Study the sigma Delta modulation & Demodulation.

**45. PHASE & FREQUENCY MODULATION / DEMODULATION (VCT-51)**

This unit facilitates students to study theory of phase and frequency modulation and demodulation techniques and also study it's different. This unit provides practical learning to th students involved in learning angle modulation concept. Expansive manuals are provided along with this unit which provides detailed experimental procedure.

**Feature:**

- \* Inbuilt power supply provided.
- \* On board Modulating signal generator.
- \* Patch chords provided.
- \* Various test and monitoring points provided on board.

**Specification:**

- \* Modulating Signal
- \* Frequency - 300Hz to 3KHz
- \* Amplitude - 0-5V
- \* Modulation Technic:
  1. Phase modulation [Direct Phase modulation]
  2. Frequency modulation [ Direct method]
    - i. Varactor diode FM.
- \* Carrier signal
  - # Frequency - 5KHz.
  - # Amplitude - 0-2V.
- \* Demodulation Technic
  - # PLL method.

**Experiments:**

To study the phase & frequency modulation and demodulation.

**46. DIODE DETECTOR (VCT-52)**

Simplest AM demodulator is the diode envelope detector in which a diode is in series with a parallel RC load. This unit provides practical training to the students involved in learning detection using diode.

**Features:**

- \* Test points provided.
- \* Detailed experimental documentation.

**Specification:**

- \* AM detected frequency - 20KHz.
- \* Weight - 1/2kg (approx).
- \* Connector type - Uninsulated socket (2mm).
- \* Dimension - H × 10, W × 80, L × 100.
- \* Cable - SP7 to BNC.

**47. PLL SECOND ORDER FREQUENCY MODULATOR & DEMODULATOR (VCT-54)**

This trainer has been developed to study the basic concept and working of PLL frequency modulation and demodulation.

**Features:**

- \* On board signal generator.
- \* Second order loop filter.
- \* Carrier recovery demodulator.
- \* Necessary test points provided to observe the various signal.
- \* Mimic diagram provided in the panel for easy understanding of various block.
- \* Built in power supply.
- \* Detailed documentation.

**Technical Specification:**

- \* Signal generator
  - # Amplitude : 0.5Vpp
  - # Frequency : 1 KHz to 15 KHz
- \* Carrier signal - VCO method
  - # Amplitude : 5Vpp
  - # Frequency : 200KHz

**Experiments:**

- \* To study frequency modulation by using PLL.
- \* To study frequency demodulation by using PLL.

**48. FREQUENCY MULTIPLIER (VCT-55)**

Frequency multiplier is an electronic system for generating multiplied range of frequencies from a fixed fine base.

**Feature:**

- \* In-Built signal generator.
- \* Built-in power supply.
- \* Various test points.
- \* Multiplied signal selector switch.
- \* Detailed documentation.

**Specifications:**

- \* Signal Generator : Square wave.
- \* Frequency : 1.25KHz.
- \* Amplitude : 5V.
- \* Multiplied signal factor : 2, 4, 8, 16, 32, 64, 128, 256.

- \* Operating supply
  - # AC : 230V / 50Hz.
  - # DC : +5V, GND.
- \* Weight : 3kg (approx).
- \* Multiple signal frequency
  - # 2.5KHz, 5KHz, 10KHz, 20KHz, 40KHz, 80KHz, 160KHz, and 320KHz.

**Experiments:**

- \* To study the frequency multiplier.

**48. FREQUENCY SYNTHESIZER (VCT- 56)**

Frequency synthesizer is an electronic system which is used to generate any range of frequency from a single fixed time base or oscillator.

**Features:**

- \* In-Built square wave generator
- \* On board frequency selector
- \* Various test points
- \* Built-in power supply

**Specification:**

- \* Signal Generator : Square wave
- \* Frequency : 1KHz
- \* Voltage : 5Vpp
- \* Synthesized signal: 1KHz to 100KHz
- \* Operating Voltage
  - # AC : 230V / 50Hz
  - # DC : +5V, GND

**Experiments:**

- To study the frequency synthesizer.

**49. SERIES AND SHUNT EQUALIZER (TBET-78)**

- \* Series Equalizer & Shunt Equalizer circuits can be performed.
- \* Built-in Power supply
- \* Provided individual 2 set of frequency components.
- \* Make provision for six your own designed components.